



Work. Play. Recycle.

# Profile USED OIL RECYCLING Container



Distributor:

## Southeastern Environmental & Waste Equip. Co. SEWE

951 Hampton Road, Columbia, SC 29209  
1-800-264-8549

Mr. Rex Norris | Office: (803)782-4898 | Cell: (803)530-8710  
Fax (803)782-0568 | E-mail: Rex@seweco.com



# Did you know that just one gallon of used oil can contaminate 1 million gallons of water?

*And that if you recycle just two gallons of oil it can generate enough electricity to run the average household for almost 24 hours!*

Cars are an indispensable fact of life for all of us. So too are abundant and clean supplies of drinking water. What we do with the used oil from our cars plays an important role in balancing our desire for convenient transportation with our desire for a clean and healthy environment today and for future generations.

Recycling your used motor oil into Profile Used Oil Containers keeps it out of our rivers, lakes, streams, ground water and away from our beaches and wild life. We all share the responsibility of protecting our environment and keeping our waters safe. Motor oil has value after it has been drained from an engine. Recycled oil saves energy. It can be reprocessed and used in furnaces for heat or in power plants to generate electricity for homes, schools, and businesses.



Collecting used oil from DIY Oil changers should be a part of every comprehensive solid waste & recycling program. Our Profile Used Oil Containers are being used in hundreds of communities across the United States to collect used oil from the DIY Oil Changers.



Collecting used oil from the Do-It-Yourself Oil Changer is easy with the Profile Used Oil Collection Containers. Conveniently located used oil drop-off sites equipped with attractive and user-friendly tanks are an essential element for any successful used oil program.



The Profile Used Oil Container is available in a 300 and 400 Gallon capacity. It's specially designed to accept used oil from the public. This attractive unit is extremely durable and very user friendly which improves program participation and aids in keeping the collection site clean.

# Profile Used Oil Container Specifications

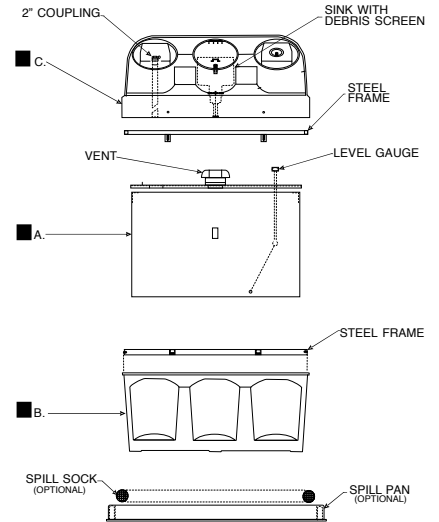
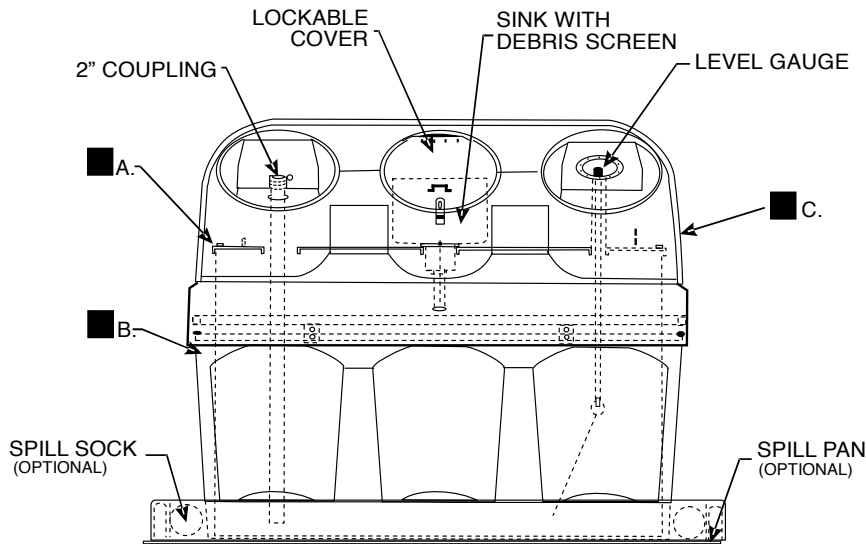

## ■ A PRIMARY TANK (40" x 60" x 40")

1. Tank body: 14 gauge commercial quality hot-rolled carbon steel, framed with 1" x 1/8" angle for additional strength.
2. Tank top: 16 gauge commercial quality hot-rolled carbon steel (36) with welded standard 2" pipe fittings and 1" turned-down flange for extra strength. Top bolted to the tank body using 3/8 - 16 wing nuts. All welding by AWS DU certified welder.
3. Exterior tank paint: Sherwin Williams machine gray industrial enamel.
4. Interior paint: epoxy/Amine modified polyamide DuPont 25 P High Solids Epoxy Mastic.
5. Venting: 2" pressure vent 5 PSIG.
6. Capacity: 400 gallons.

## ■ B SECONDARY CONTAINMENT BASIN (50" x 71" x 30")

A one-piece molded fiberglass construction permanently fuses a smooth outer surface of solid UV-stabilized gelcoat to a substrate of fiberglass strand reinforcement randomly oriented and thoroughly impregnated with orthothalic thermo-setting resin. With an overall wall thickness of 3-5mm, and a glass content of 30-35%, the polyester-glass laminated body is reinforced with a steel frame which connects the Protective Access Housing (c) to the Secondary Containment Basin (B).

## ■ C PROTECTIVE ACCESS HOUSING (50" x 71" x 31")

A one-piece molded fiberglass construction permanently fuses a smooth outer surface of solid UV-stabilized gelcoat to a substrate of fiberglass strand reinforcement, randomly oriented and thoroughly impregnated with orthothalic thermo-setting resin. With an overall wall thickness of 3-5mm, and a glass content of 30-35%, the polyester-glass laminated body is reinforced with a steel frame which connects the Protective Access Housing (C) to the Secondary Containment Basin (B).

Standard labeling: "Recycle Used Oil Here", "Level Meter", EPA Oil Drop Symbols, as well as Step by Step instructions.



## Features:

- Sink: a two (2) gallon fiberglass funnel forms a deep built-in drainage sink allowing for quick pouring without backup or overflow
- Screen: a removable debris screen fitted to the bottom of the sink prevents clogging.
- Cover: a lockable rain-tight cover fits over the funnel.
- Gauge: The Therma Type H Level gauge is a reliable, swing arm type tank gauge used for monitoring the oil level inside the primary tank. It's simple mechanical design promotes durability, minimal upkeep, quick installation, and easy/inexpensive repairs. This liquid level gauge is custom made to fit our tank and contains an aluminum lock nut, galvanized steel lifting rod and HDPE Float. It's located directly behind a 4" clear acrylic window in a protected indentation of the secondary containment user panel.
- Coupling: a 2" universal coupling with lockable dustcap located in a protected indentation on the outside of the container facilitates emptying the primary tank.

# Profile Used Oil Container



The Profile Oil Container combines the unique feature of a steel inner tank surrounded by a rust resistant fiberglass secondary containment.

## Other features include:

1. Large disposal funnel w/ removable debris screen
2. Weather proof lockable lid
3. Level gauge
4. Bilingual instruction & recycling decals
5. Industry standard 2" quick service coupling
6. Rear access service panel
7. Tertiary containment spill pan
8. Oil absorbent spill sock
9. High gloss easy clean gel coat finish
10. Wide variety of standard and custom colors

Model	Profile Oil Container
Code	6300
Capacity	300 gal.
Weight	500 lbs.
Dimension	71" x 52" x 61"

Model	Profile Oil Container
Code	6400
Capacity	400 gal.
Weight	590 lbs.
Dimension	71" x 52" x 61"

Model	Profile Tertiary Containment Spill Pan
Code	6849
Capacity	
Weight	40 lbs.
Dimension	81" x 67" x 6"

Model	Oil Absorbent Spill Sock - 10 ft.
Code	1610
Capacity	
Weight	12 lbs.
Dimension	5" dia. x 10'